

breezesta™

PIEDMONT LOUNGE CHAIR
PT-0500

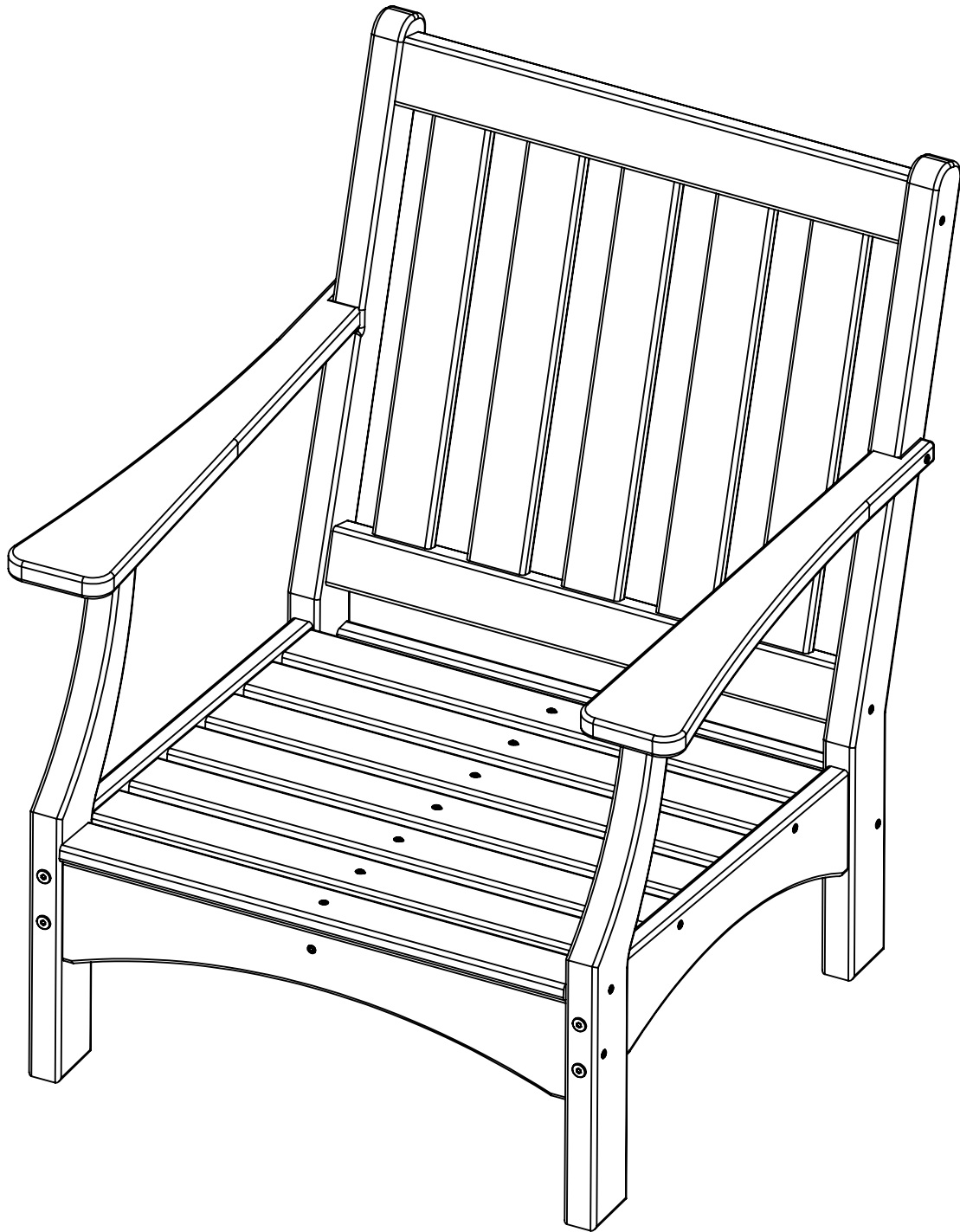

REV01-4/19

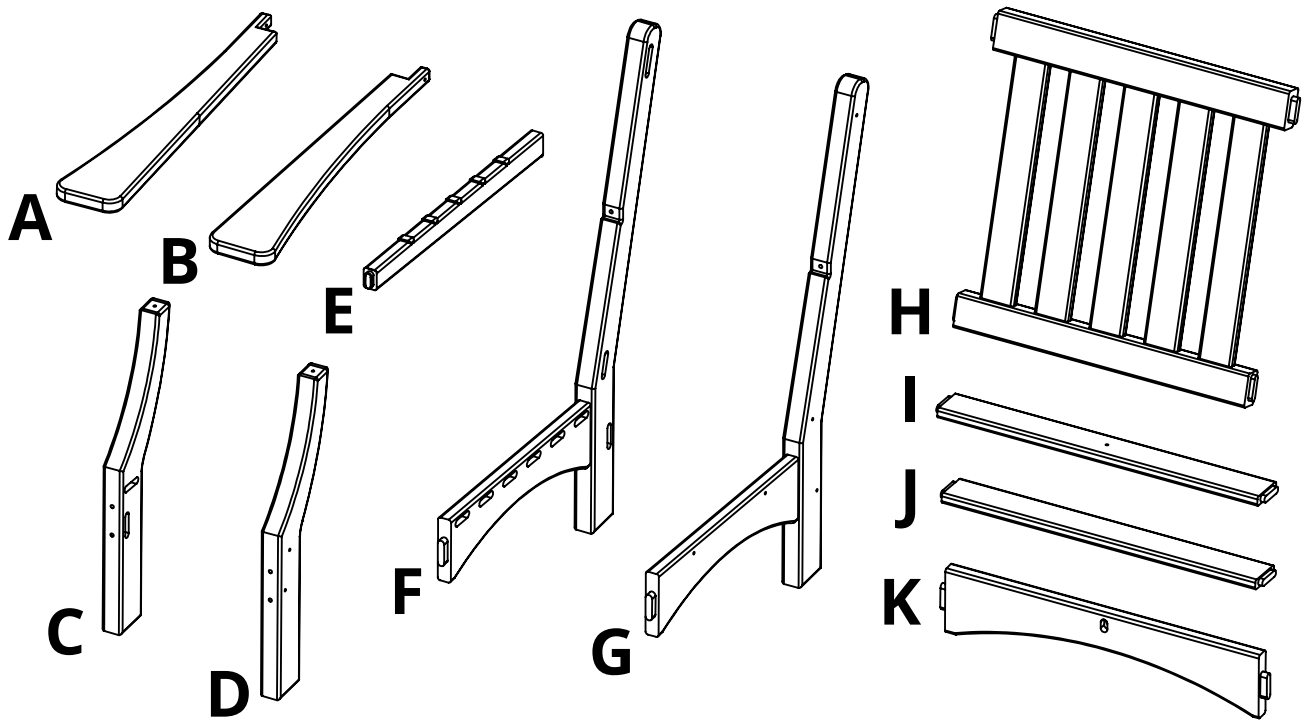

PARTS			
PART	DESCRIPTION	PART NO.	QTY
A	LEFT ARM	PRT-00454	1
B	RIGHT ARM	PRT-00455	1
C	LEFT FRONT LEG	PRT-00452	1
D	RIGHT FRONT LEG	PRT-00453	1
E	SEAT SUPPORT	PRT-00457	1
F	LEFT SIDE ASSEMBLY	SA-00236	1
G	RIGHT SIDE ASSEMBLY	SA-00237	1
H	BACK ASSEMBLY	SA-00234	1
I	DS LOUNGE CHAIR SEAT SLAT	SS-24.5	6
J	DS LOUNGE CHAIR FRONT SLAT/ OTT	SS-24	1
K	FRONT/BACK SPREADER	PRT-00456	2

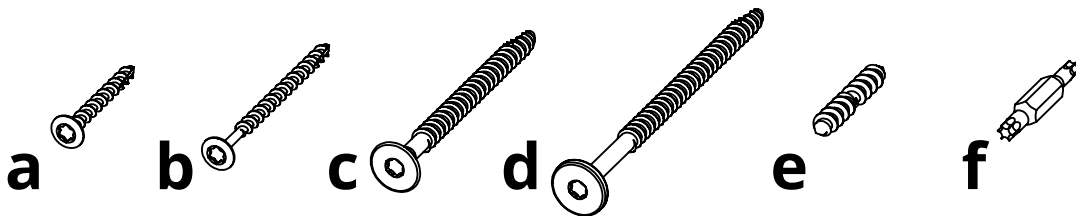

HARDWARE			
PART	DESCRIPTION	PART NO.	QTY
a	#8 X 1-1/2" TORX SCREW	H-0000-S815	15
b	#8 X 2-1/2" TORX SCREW	H-0000-S825	10
c	1/4"-10 X 3" LAG SCREW	H-0000-S103	2
d	1/4"-10 X 4" LAG SCREW	H-0000-S104	4
e	DOUBLE SCREW	H-0000-DS	2
f	T20 & T25 TORX BIT	H-0000-CTD	1

Suggested Tools: Drill, Plastic Mallet

Please read entire instructions before beginning

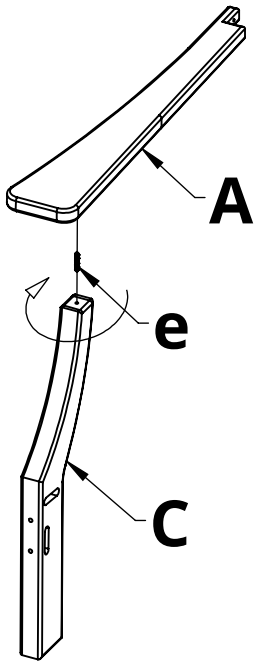

1. Attach Part A to Part C with Hardware e by rotating Part A clockwise, stopping when the assembly is tight

2. Repeat Step 1 with Parts B & D

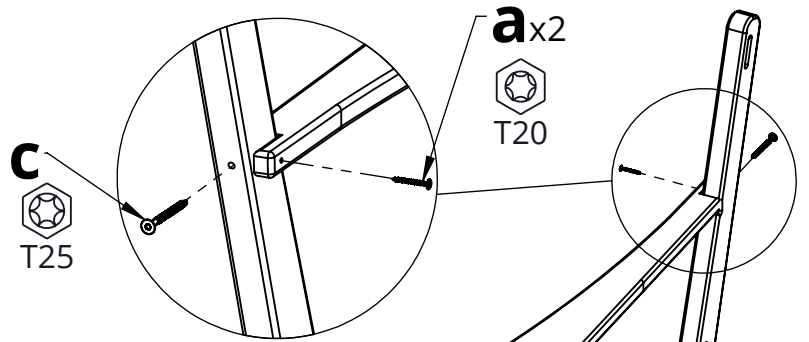

3. Connect Part F to the assembly of A & C using the hardware shown

4. Repeat Step 3 with Part G & the assembly of B & D

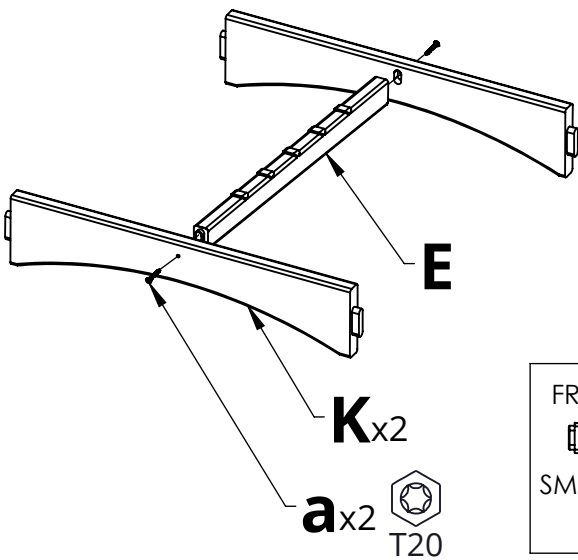
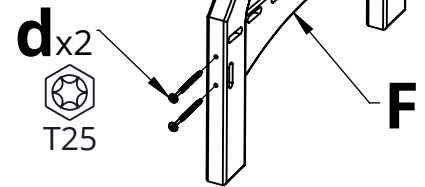

5. Attach Parts K to Part E using Hardware a

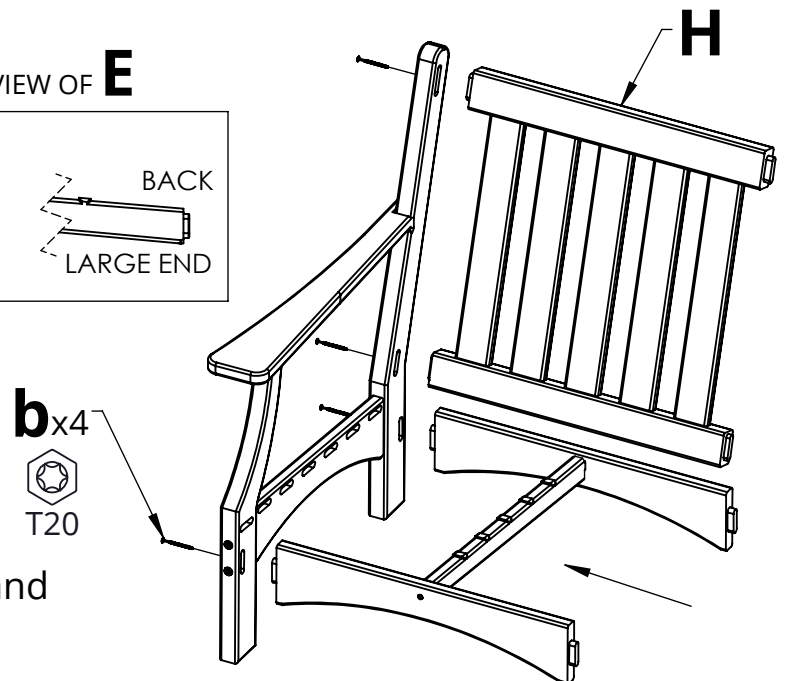
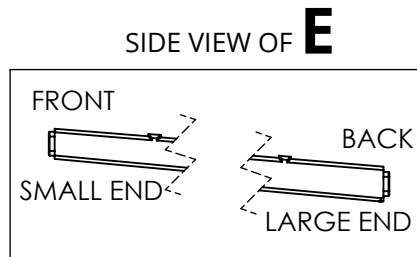

6. Connect the previous assemblies and Part H using Hardware b

7. Place Parts I & J into the mortise as shown

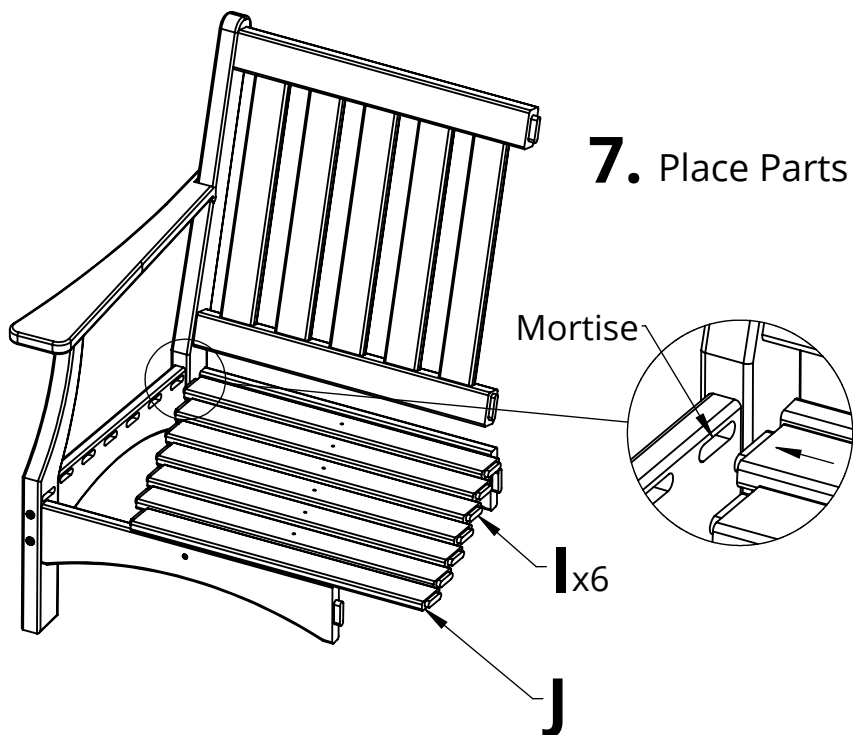

8. Attach the other side assembly using the hardware shown

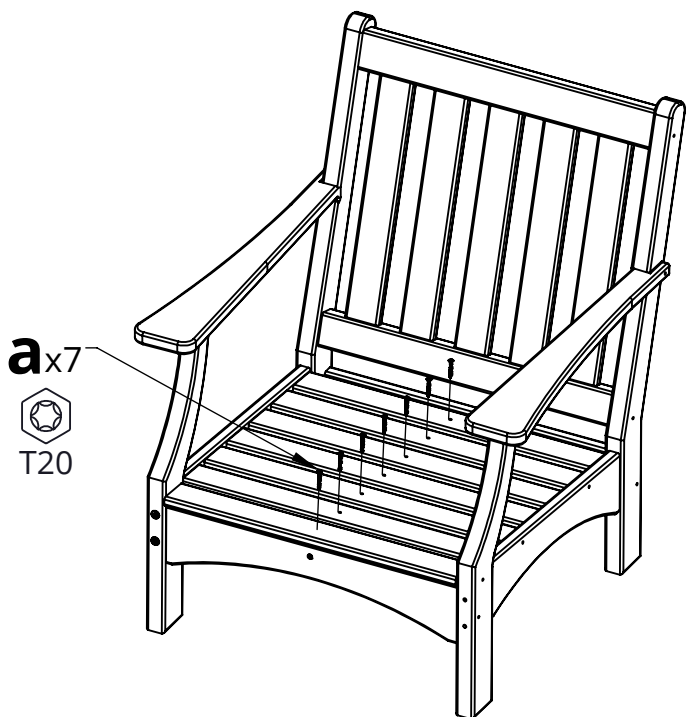
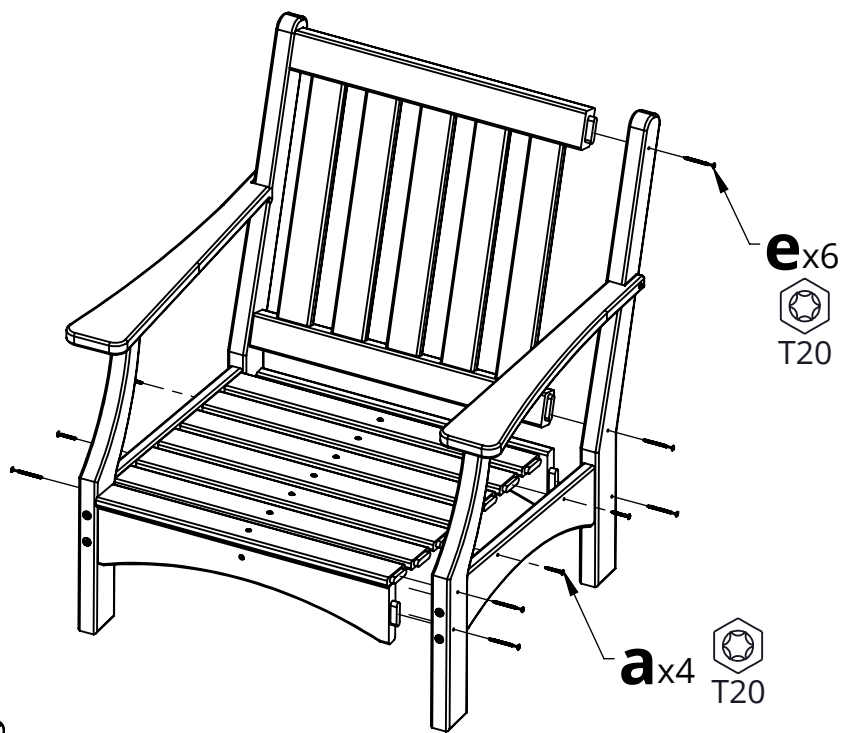

9. Connect Parts I & J using Hardware a